

Z3

HIGH GRADE ZINC

PRODUCT DATA

DESCRIPTION

BZL Brand Z3 is a high grade zinc with a maximum of 0.05% total named impurities.

PRINCIPAL USES

Continuous galvanizing of sheet and wire products

Production of brass, zinc oxide and zinc dust

General electro plating

CHEMICAL DATA

Zinc Purity **99.95%** NOMINAL

BZL	Lead	0.03%
Brand Z3	Cadmium	0.01%
Impurity Levels	Iron	0.01%
Max Wt%	Tin	0.001%
	Copper	0.002%
	Arsenic	0.0005%
Total Named impurities		0.05%

NATIONAL STANDARDS

BZL-Z3 conforms to:

Euro Norm	EN 1179:1995 GRADE Z3
USA	ASTM B6-77 (83) HG
Australia	AS1242 1985 Zn 99.95
International	ISO 752 1981 Zn 99.95

GENERAL DATA

Brand	BZL
Supply	1 Tonne Pallet (40 x 25 kg Plates) 1400 kg Block
Stacking	Pallets - Six High Max Blocks - Seven High Max

Refer to "Health and Safety - Zinc"
for safe handling requirements

IDENTIFICATION

Z3 product is marked with a green colour code.
All product is traceable to production records using reference numbers marked on zinc during manufacture.

In plate form this product is Embossed Z1 and should always be identified by the colour code only.

Kingsweston Lane, Avonmouth
Bristol BS11 8HT, England
Tel: +44(0)117 980 2500
Fax: +44(0)117 980 2599
Sales Fax: +44(0)117 980 2593
<http://www.bzl.co.uk>

Z3

HIGH GRADE ZINC

WEIGHTS & DIMENSIONS

25 kg PLATE
All pallets are steel strapped
in four positions.

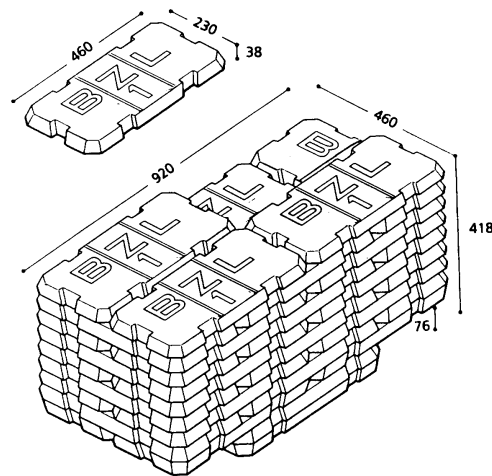

1400 kg Block

